

Module 3

Extended Period Simulation, Water Quality Modeling and Model Calibration

Introduction to EPANET Water Distribution Modeling

EWRI WORLD ENVIRONMENTAL AND WATER RESOURCES CONGRESS

June 5, 2018

Minneapolis, MN

Going from Steady State to EPS

- In steady state we are looking at the system at a snapshot in time. Useful for some simulations:
 - Sizing facilities for peak conditions
 - Performing some fire flow analyses, etc.
- In EPS we look at the system over a period of time
 - Much more realistic.
 - Opens up a wide range of applications.
 - Required for water quality applications

Developing an EPS Model

- Start with a steady state representation and ADD
 - Specify duration, time step and optionally, other time-related values
 - Provide temporal demand patterns
 - Specify initial conditions (e.g., pump is open)
 - Specify rules (controls) for pumps and valves
 - Additional tank info that was not mandatory or not fully specified in steady state

Time Varying Demands

- In steady-state you define a single demand usage (typically base demand)
- In EPS you define time varying demand patterns which are multipliers of the base demand

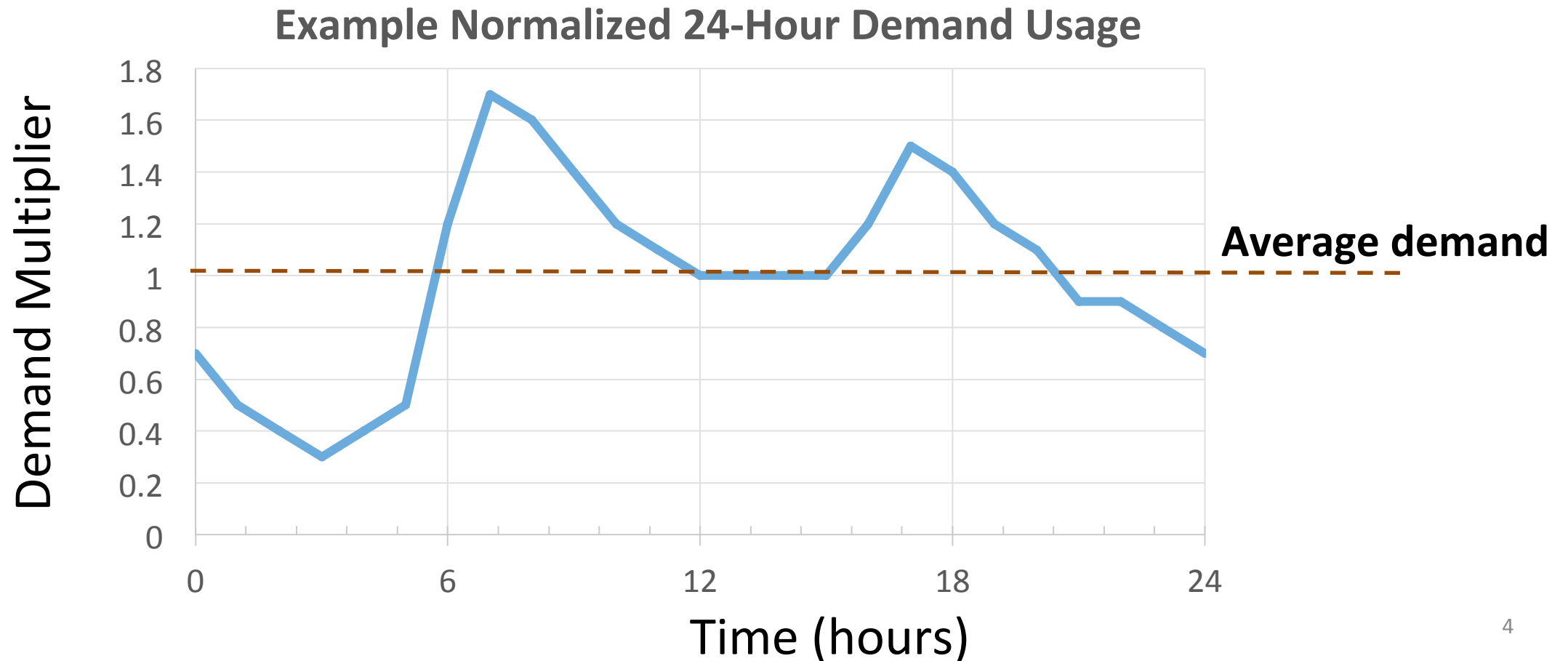

Demand Patterns

- Concept: A limited number of distinct temporal water demand patterns, each assigned to one or multiple demand nodes
- Demand patterns are composed of multipliers that are applied to base demands assigned to nodes
- Patterns represent different uses or different areas
 - Usage types (residential, industrial, etc.)
 - Geographic areas (pressure zones, regions, DMAs, etc.)
 - Water demand type (Average day, peak day, etc.)
 - Specific major water users

Demand Patterns

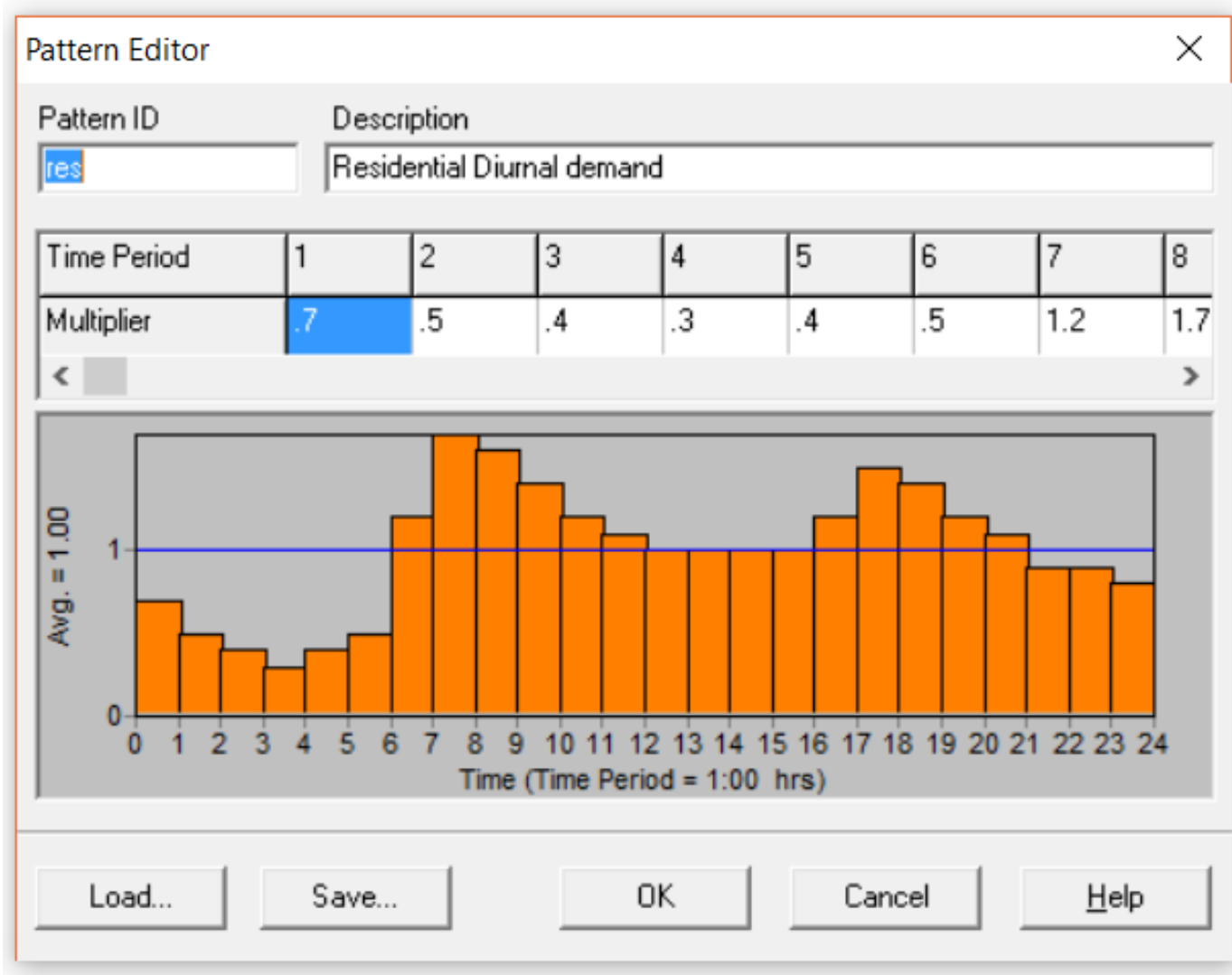

- Multipliers are assigned at a fixed time interval starting at midnight or other times as defined under Options-Time
- Each pattern has a unique Pattern ID
- Patterns can be saved as text files (.PAT) for later loading

Example Use of Patterns

As an example of how time patterns work consider a junction node with an average demand of 10 GPM. Assume that the time pattern interval has been set to 4 hours and a pattern with the following multipliers has been specified for demand at this node:

Period	1	2	3	4	5	6
Multiplier	0.5	0.8	1.0	1.2	0.9	0.7

Then during the simulation the actual demand exerted at this node will be as follows:

Hours	0-4	4-8	8-12	12-16	16-20	20-24	24-28
Demand	5	8	10	12	9	7	5

If the duration of the simulation exceeds the time duration of the pattern, then the pattern repeats itself.

Repeating
pattern

Determining Demand Patterns

- Use literature values
 - Be careful because patterns may vary drastically by region or locally
- Use information available from some water utilities
- For major users, measure temporal demand patterns
- Calculate temporal patterns system-wide or by DMAs or Zones

Calculating System-wide Usage

Flow Balance Method:

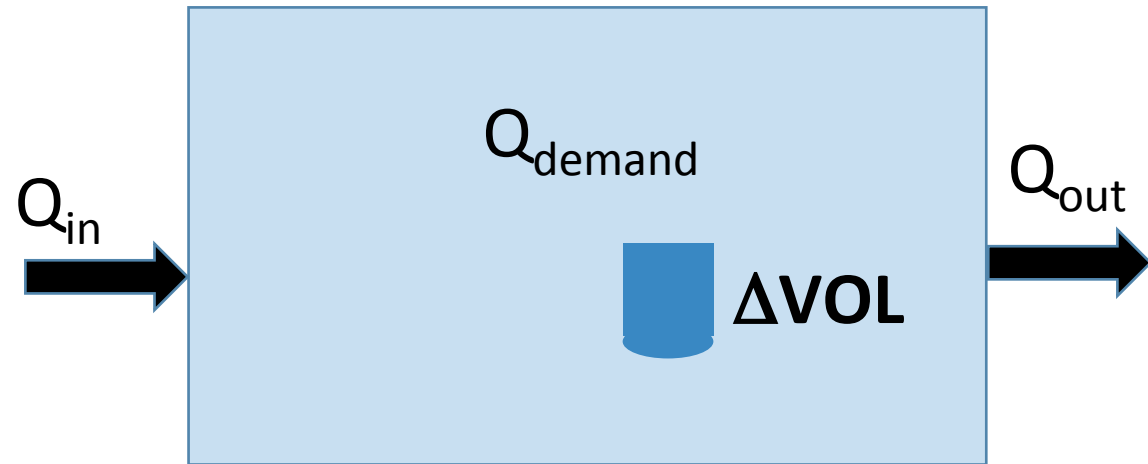

$$Q_{demand}(T) = Q_{in}(T) - Q_{out}(T) - [VOL_{tank}(T) - VOL_{tank}(T-1)]$$

Calculate usage for each time period (T) and
normalize by dividing by average demand

Calculating Usage by District Metering Areas (DMA)

DMA's are contiguous areas in distribution systems which can be separated by flow meters so that usage can be calculated for each DMA

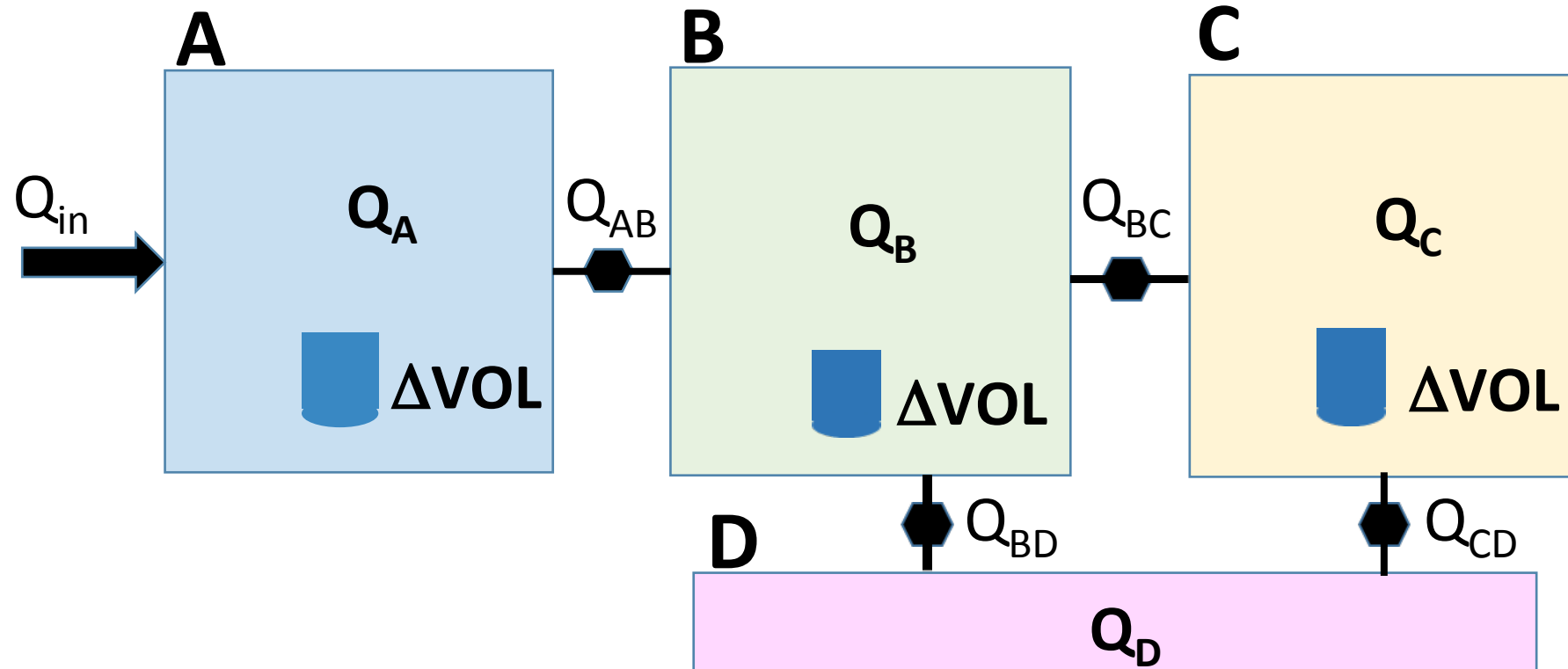

Calculate Q_A , Q_B , Q_C and Q_D by flow balance for each time step

Controls (Rules)

- Controls are statements that determine how the network is operated over time.
- They specify the status of selected links as a function of time, tank water levels, pressures, etc. at select points within the network.
- There are two categories of controls that can be used:
 - Simple controls
 - Rule-Based controls
- Controls are entered in the Control section in the browser as unformatted text statements.

Simple Controls

- Simple controls change the status or setting of a link based on:
 - the water level in a tank
 - the pressure at a junction
 - the time into the simulation
 - the time of day
- There is no limit on the number of simple control statements that can be used

Examples of Simple Controls

CONTROL STATEMENT	MEANING
LINK 12 CLOSED IF NODE 23 ABOVE 20	Close Link 12 when the level in Tank 23 exceeds 20 ft.
LINK 12 OPEN IF NODE 130 BELOW 30	Open Link 12 if the pressure at Node 130 drops below 30 psi
LINK 12 1.5 AT TIME 16	Set the relative speed of pump 12 to 1.5 at 16 hours into the simulation
LINK 12 CLOSED AT CLOCKTIME 10 AM LINK 12 OPEN AT CLOCKTIME 8 PM	Link 12 is repeatedly closed at 10 AM and opened at 8 PM throughout the simulation

Rule-Based Controls

- Rule-Based Controls allow link status and settings to be based on a combination of conditions that might exist in the network after an initial hydraulic state of the system is computed.
- Expressed as a series of IF, AND, OR, THEN statements
- No limit on the complexity of the compound statements
- Provides wide range of freedom to formulate rules

Rule-Based Controls Example #1

This set of rules shuts down a pump and opens a by-pass pipe when the level in a tank exceeds a certain value and does the opposite when the level is below another value.

RULE 1
IF TANK 1 LEVEL ABOVE 19.1
THEN PUMP 335 STATUS IS CLOSED
AND PIPE 330 STATUS IS OPEN

RULE 2
IF TANK 1 LEVEL BELOW 17.1
THEN PUMP 335 STATUS IS OPEN
AND PIPE 330 STATUS IS CLOSED

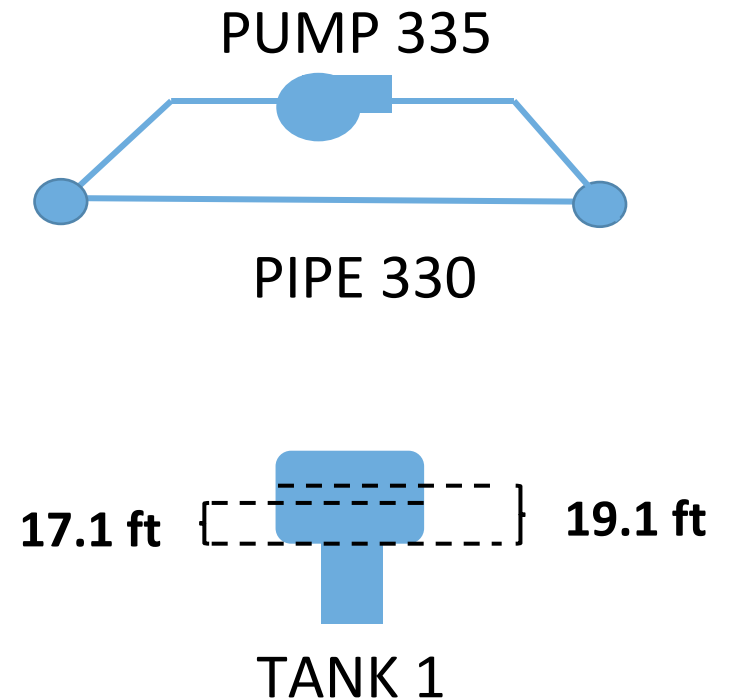

Rule-Based Controls Example #2

These rules change the tank level at which a pump turns on depending on the time of day

RULE 3

IF SYSTEM CLOCKTIME \geq 8 AM
AND SYSTEM CLOCKTIME $<$ 6 PM
AND TANK 1 LEVEL BELOW 12
THEN PUMP 335 STATUS IS OPEN

RULE 4

IF SYSTEM CLOCKTIME \geq 6 PM
OR SYSTEM CLOCKTIME $<$ 8 AM
AND TANK 1 LEVEL BELOW 14
THEN PUMP 335 STATUS IS OPEN

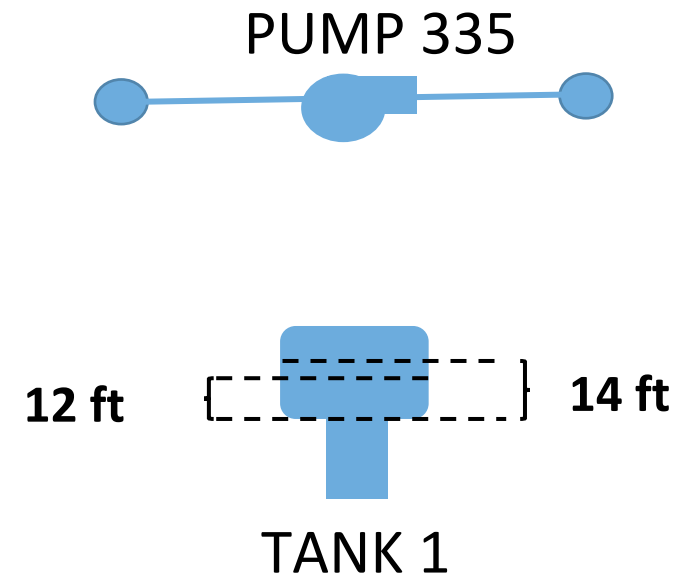

Representing Tanks in EPS

- Same information required for steady-state runs
- Though tank information is required for steady-state runs, some of the information is not actually used in most steady-state runs (e.g., diameter, minimum and maximum levels, volume-water level curves)
- Check that tank information from steady state runs is complete and accurate to support EPS runs.

Uses of EPS Mode

- Support of water quality modeling
- Sizing water tanks
- Pump operations
- Energy usage
- Any situation where you are trying to represent the water system over time!

Water Quality Modeling

- Flows and velocities are calculated by model. This information is used to calculate water quality.
- Water quality modeling is done only in extended period simulation mode (not steady state)
- Water quality modeling processes:
 - Transport (plug flow ignoring dispersion)
 - Fate:
 - Bulk reactions
 - Wall reactions
 - Tank hydrodynamic mixing

Uses of Water Quality Models

- Design
 - Checking impacts of a new tank
 - Adding disinfection booster station
- Operation
 - Adjusting disinfectant feeds
 - Selecting disinfectant type
- Hindcasting
 - Recreating complaints
 - Litigation cases

Types of Water Quality Modeling

- Water age
- Source tracing
- Constituents
 - Conservative substances
 - Non-conservative substances
 - Examples: Chlorine , DBPs

Water Age

- Water age modeling is the modeling of the time history of age of water at each node
- Water age is frequently used as a surrogate for water quality
 - new water → good / old water → bad
- Age is influenced by residence times in tanks and travel times through pipes
- Age is typically highest in dead ends, downstream of a series of tanks and at nodes at the far end of the distribution network

Maximum Water Age

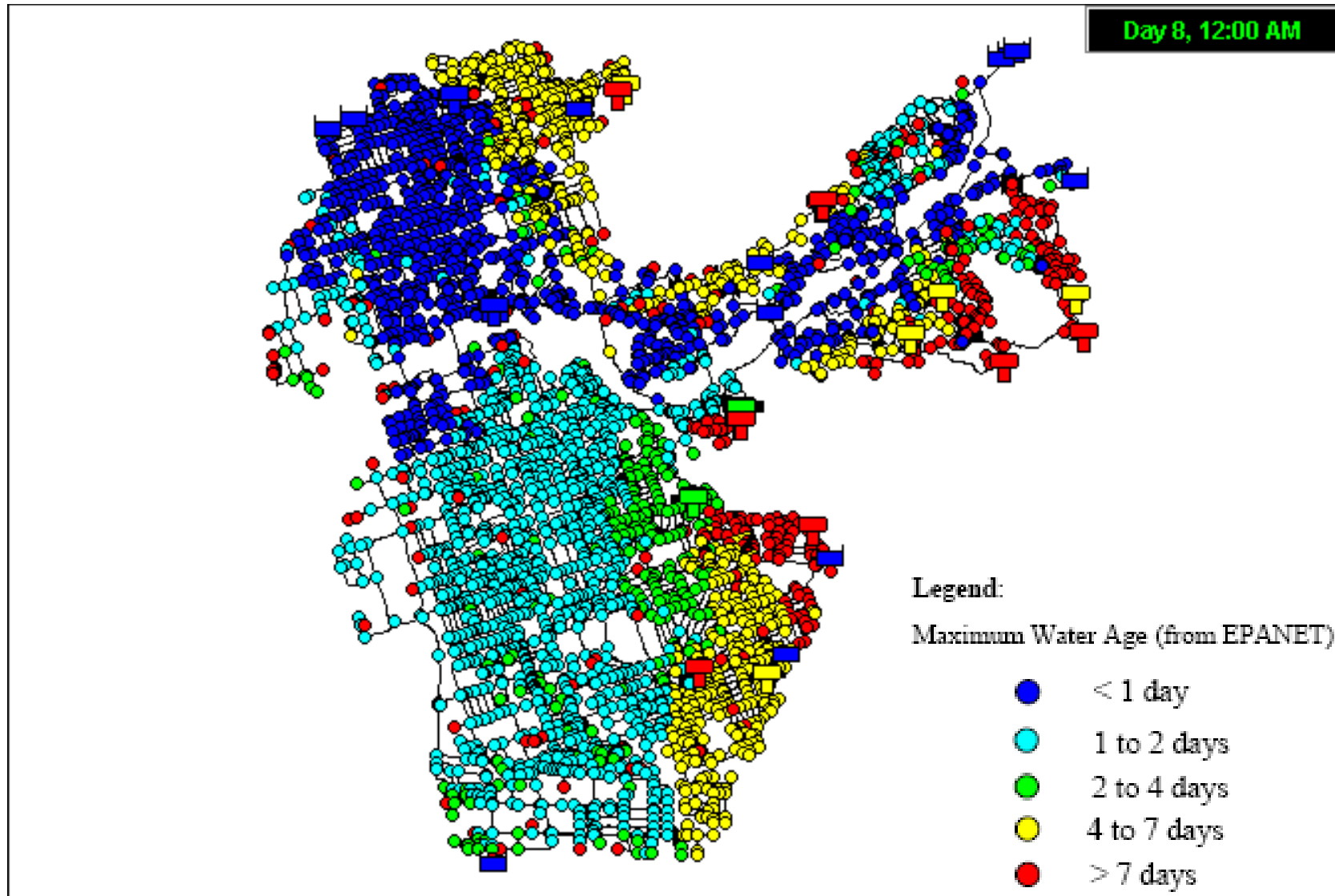

Source Tracing

- Relevant to water systems with multiple sources
- Tracing % of water coming from a single source to all points in the distribution system over time
- Multiple runs needed to trace multiple sources

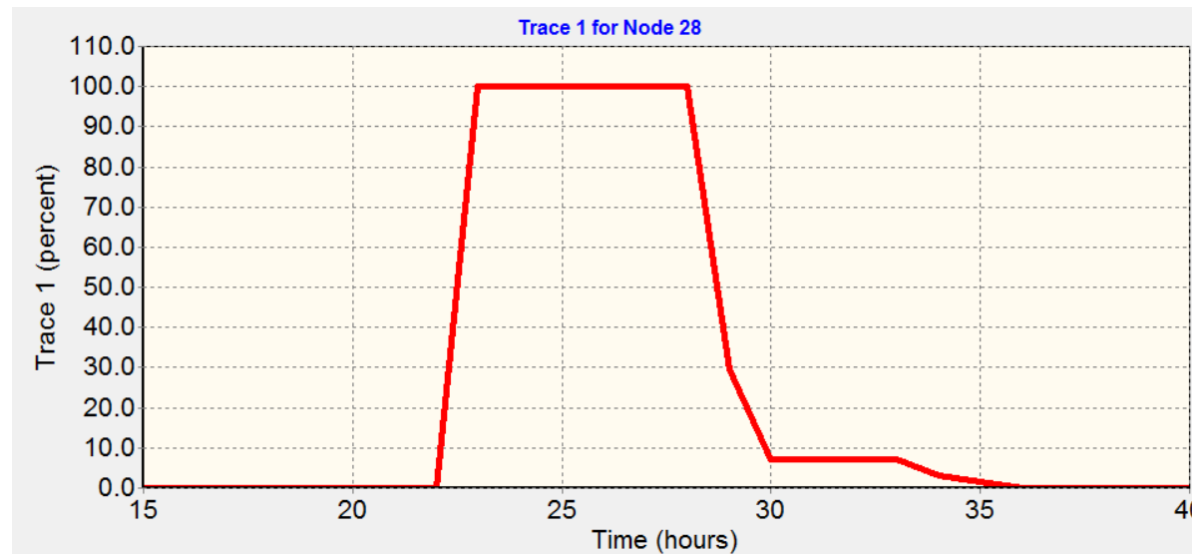

Source Water Tracing (based on 3 separate runs)

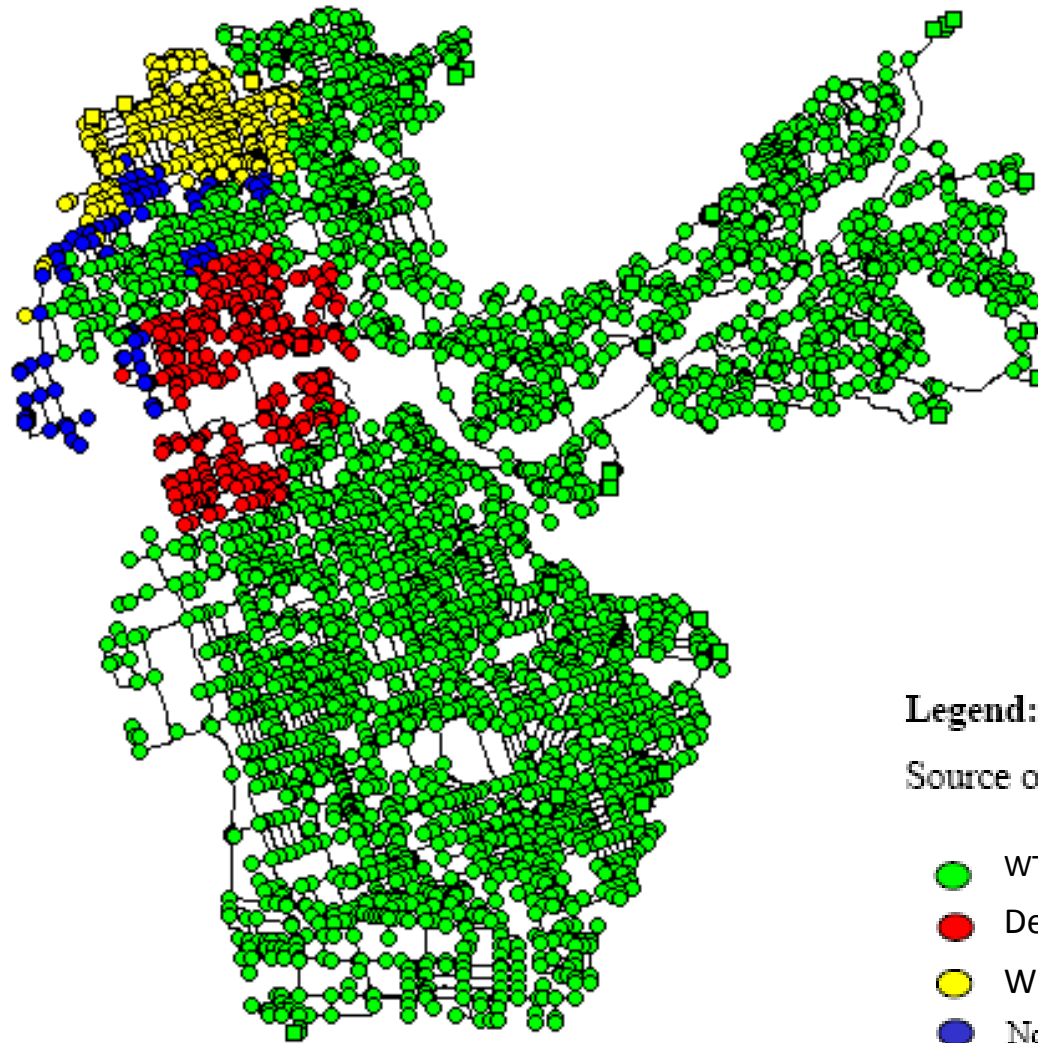

Legend:

Source of majority of water from:

- WTP
- Demineralization Plant
- Wells
- No majority: Combination of all 3 sources

Constituent Modeling

- Simulate the concentration of constituents in water at all points in the distribution system
- Conservative substances: Concentration of conservative substances only affected by mixing (for example, fluoride)
- Non-conservative substances: Concentration changes due to growth or decay
 - Chemical, biological & physical processes
 - Represented by different mathematical transformations

Water Quality Processes in Pipes

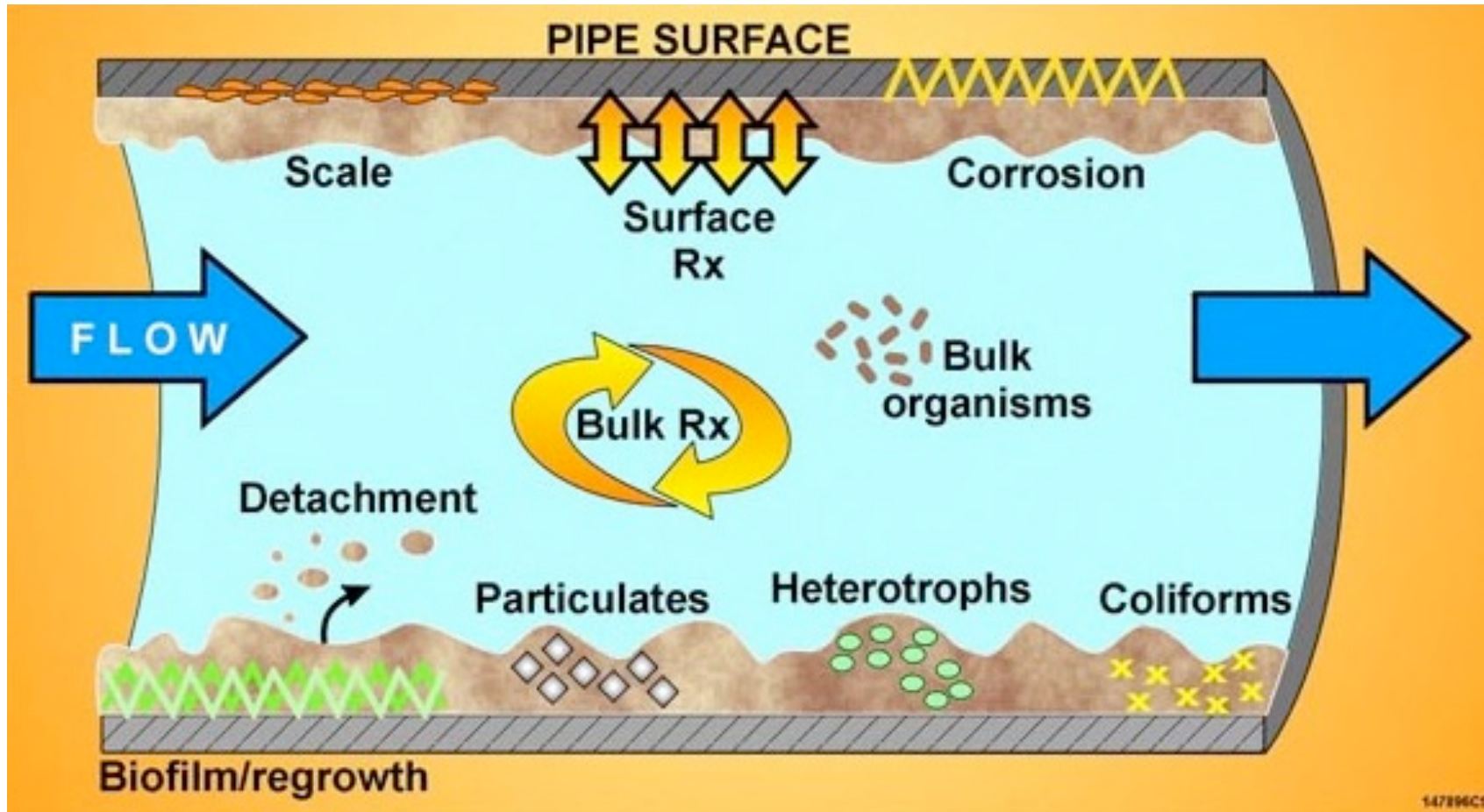

Source: Center for Biofilm Engineering, MSU, Bozeman

Modeling Non-Conservative Substances

- Non-conservative constituents that are frequently modeled
 - Chlorine & chloramines
 - DBPs (Trihalomethanes)
- Most common types of transformations
 - First order decay
 - Zero order growth or decay
 - First-order growth to equilibrium

Chlorine Modeling

- Most common water quality constituent modeled
- Predict the chlorine residual throughout the distribution system
- Can vary significantly during the day

Bulk Decay

- Bulk decay: decay in flowing water
- Usually represented as first order decay
$$C_t = C_0 e^{-kt}$$
- Decay rate
 - depends on water quality characteristics
 - independent of pipe material
- Negative sign for k indicates decay
- Range of decay coefficients: -0.05 to -15 per day
 - Equivalent to half life of 14 to 0.05 days
- Most typical range is -0.2 to -1.0 per day
 - Equivalent to half life of 3.5 to 0.7 days

Wall Decay

- Wall decay: Interaction of water with wall
- Due to corrosion, biofilm, and other processes at the wall
- Depends on pipe material
- Rate of loss of chlorine at wall depends upon
 - wall decay coefficient
 - rate at which mass is transferred to the wall
- The wall decay coefficient can be determined from literature values or through field studies.
- Generally not a factor in tanks & reservoirs
 - ratio of wall to volume is usually very small

Modeling Tank Mixing

- Tank mixing represented by 4 alternative theoretical mixing models
- No tanks operate exactly as one of the theoretical models

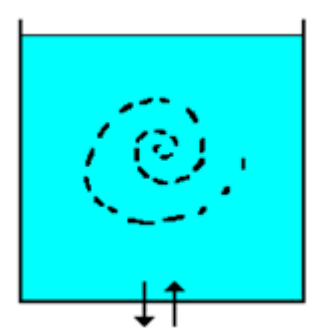

**Complete
Mix**

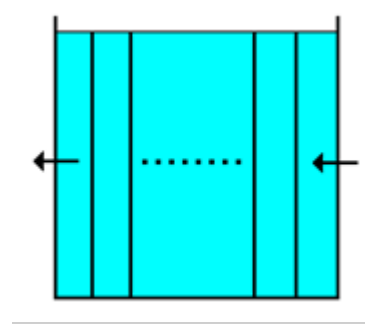

**Plug Flow
FIFO**

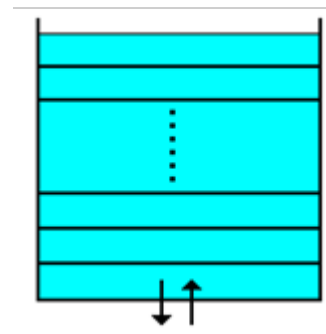

**Plug Flow
LIFO**

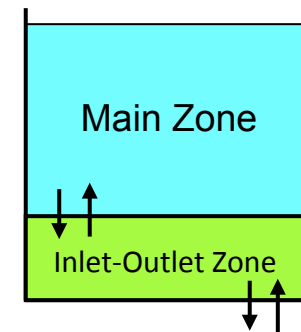

**Two
Compartment**

Running a Water Quality Model

- 1) Start with calibrated hydraulic EPS model
- 2) Select the total duration of the run
- 3) Select the parameter to be modeled (Age, trace or constituent)
- 4) For trace and non-conservative constituents, define required parameters
- 5) For each tank, choose a mixing model
- 6) Define source concentrations
- 7) Set initial conditions
- 8) Run the model and look at results

What is Calibration?

- **Compare model results to field sampling data**
 - Pressure testing
 - Fire Hydrant tests
 - SCADA data
 - Water quality measurements
- **Adjust model parameters so that model results more closely represent observed results**
- **Necessary step to develop confidence in model results**

Steady-State and EPS Calibration

Steady-state calibration

- Use of targeted field tests
 - Using fire flow data
 - Specific pressure tests
 - C-value testing
 - Flow tests to confirm demand

EPS calibration

- Calibrating an entire area (system or pressure zone) to recorded data captured by SCADA or other methods
- Comparing overall system performance to model results
 - Using SCADA
 - Wide-scale field studies

Validation

- Calibration only ensures that the model matches a specific set or sets of field data.
- In validation you apply the calibrated model to a different scenario (i.e., an independent data set) and check that the calibrated model parameters apply to other scenarios
- Use an existing “calibrated” model and create a new scenario from it. Needs less effort to “calibrate” the new scenario.
 - For example: Start with an average day model and create a maximum hour scenario

Urban Watersheds Research Institute, and
National Center for Infrastructure Management & Modeling



present a class/workshop on

Water Distribution Systems Modeling Using *EPANET*

When: Thursday and Friday, September 20 & 21, 2018; 8:30 am - 5:00 pm

Where: U.S. Environmental Protection Agency AWBERC Research Center
26 W. Martin Luther King Dr., Cincinnati, OH 45268

About this Class:

A 2-day (14 hour) class on how to analyze and design municipal water distribution systems using the latest version of EPANET software. This software is available at no cost from the U.S. Environmental Protection Agency (EPA).

The class is composed of 10 modules that include lectures, demonstrations, and hands-on exercises in a workshop format. The class is designed for engineers, planners and water systems operators ranging in experience from novice to experienced modelers and offers opportunities to learn how to use/apply this model, and to improve individuals' skills. Class modules:

- | | |
|--|---|
| (1) Theory, history of modeling | (2) Constructing a basic steady state model. |
| (3) Pumps, tanks, valves and sources. | (4) Using GIS/CAD to construct a network model. |
| (5) Steady state calibration. | (6) Extended period simulations. |
| (7) SCADA, field data and calibration. | (8) Water quality. |
| (9) Other operational applications. | (10) Other EPANET related resources |

<https://www.regonline.com/EPANET-Intro2018>

SmallWater USA

- Simple hypothetical model
- Population: 2700
- Pipe material: cast iron, A-C, PVC
- Two sources
 - Primary: Surface water purchased
 - Secondary: Well field
- Two tanks:
 - 50,000 gal elevated tank & 165,000 gal standpipe
- Water usage: Avg. 210,000 gpd; Max 400,000 gpd
- Three pressure zones: main, high & reduced

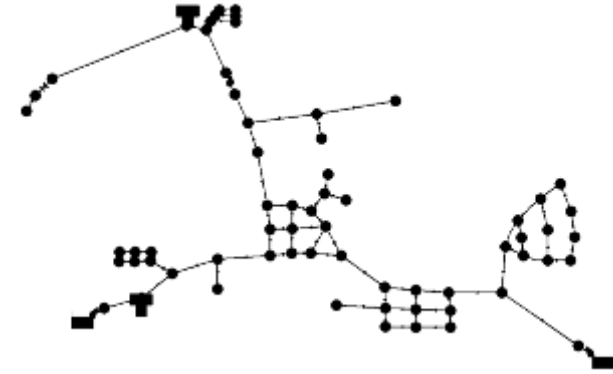

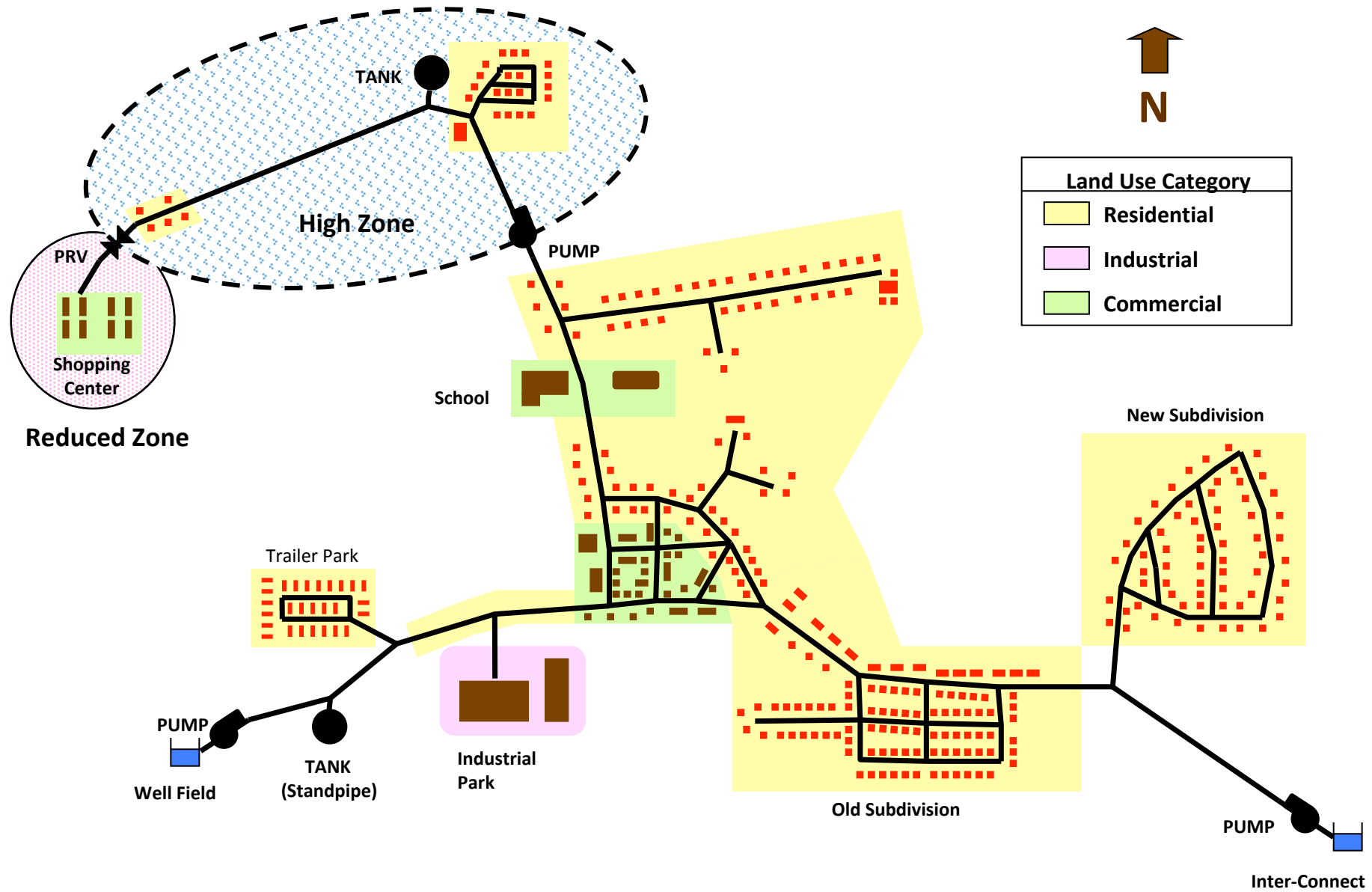

Average Demand (gpm)

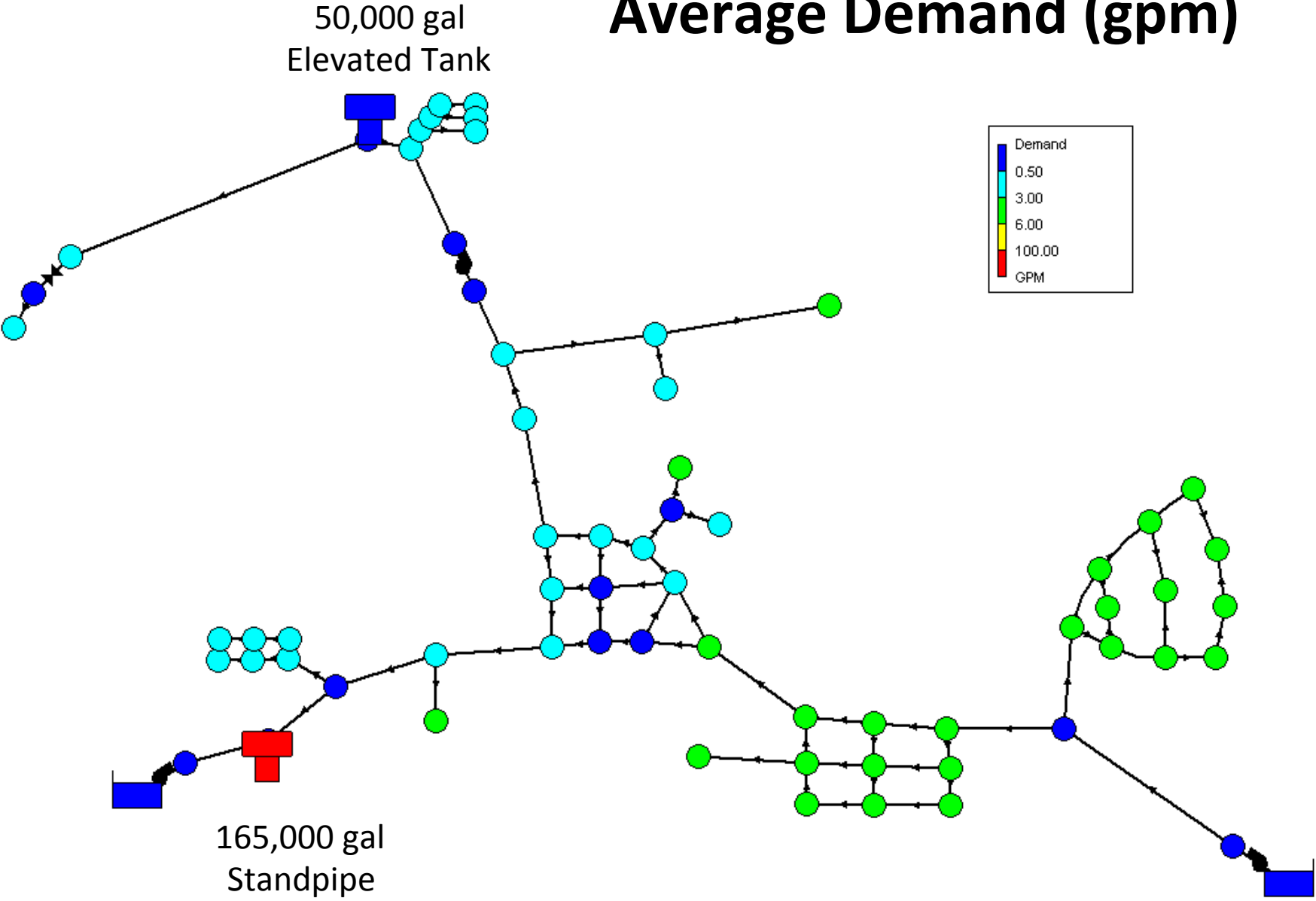

Pipe Diameters (in)

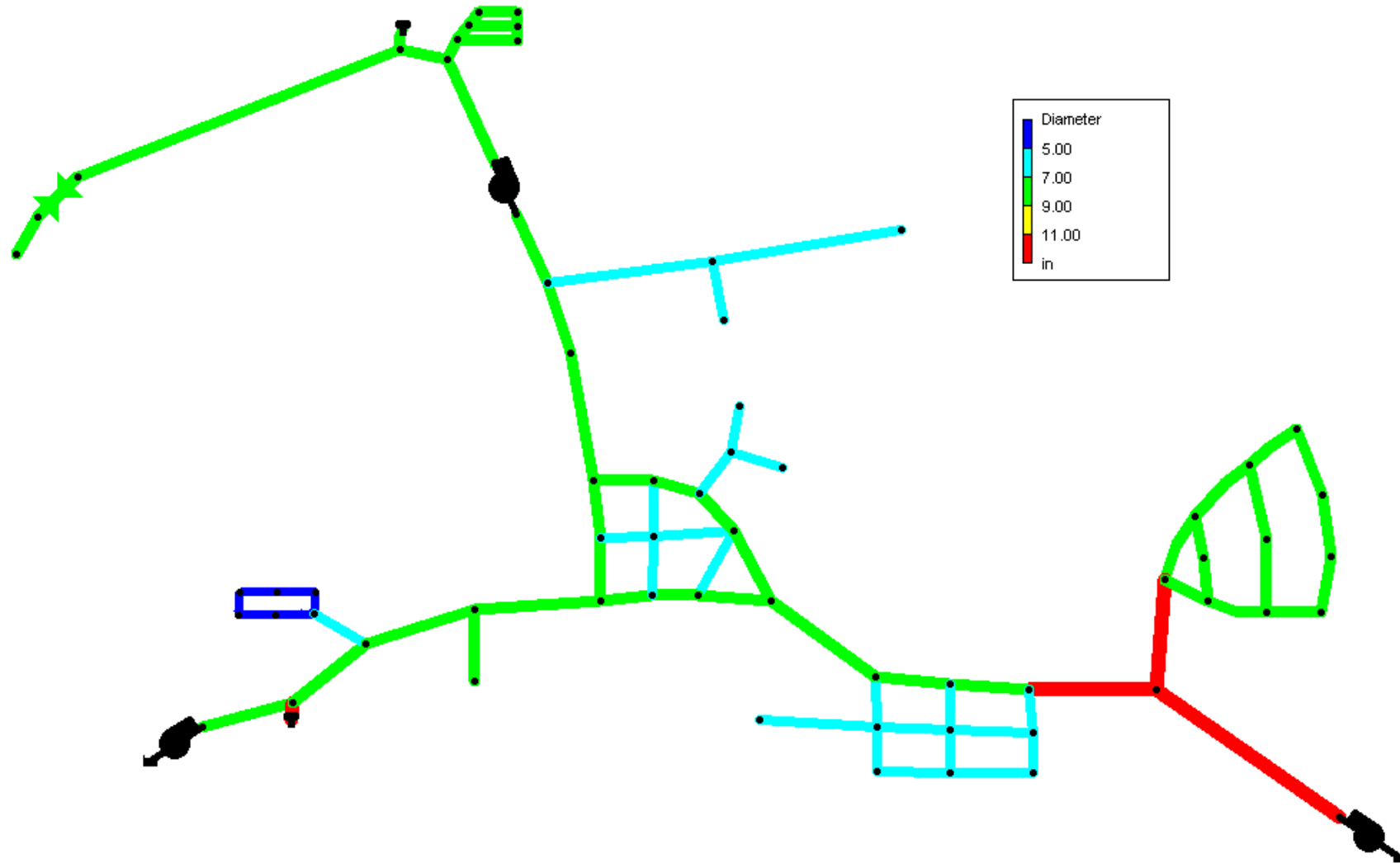

Flow from Two Sources (Max Day)

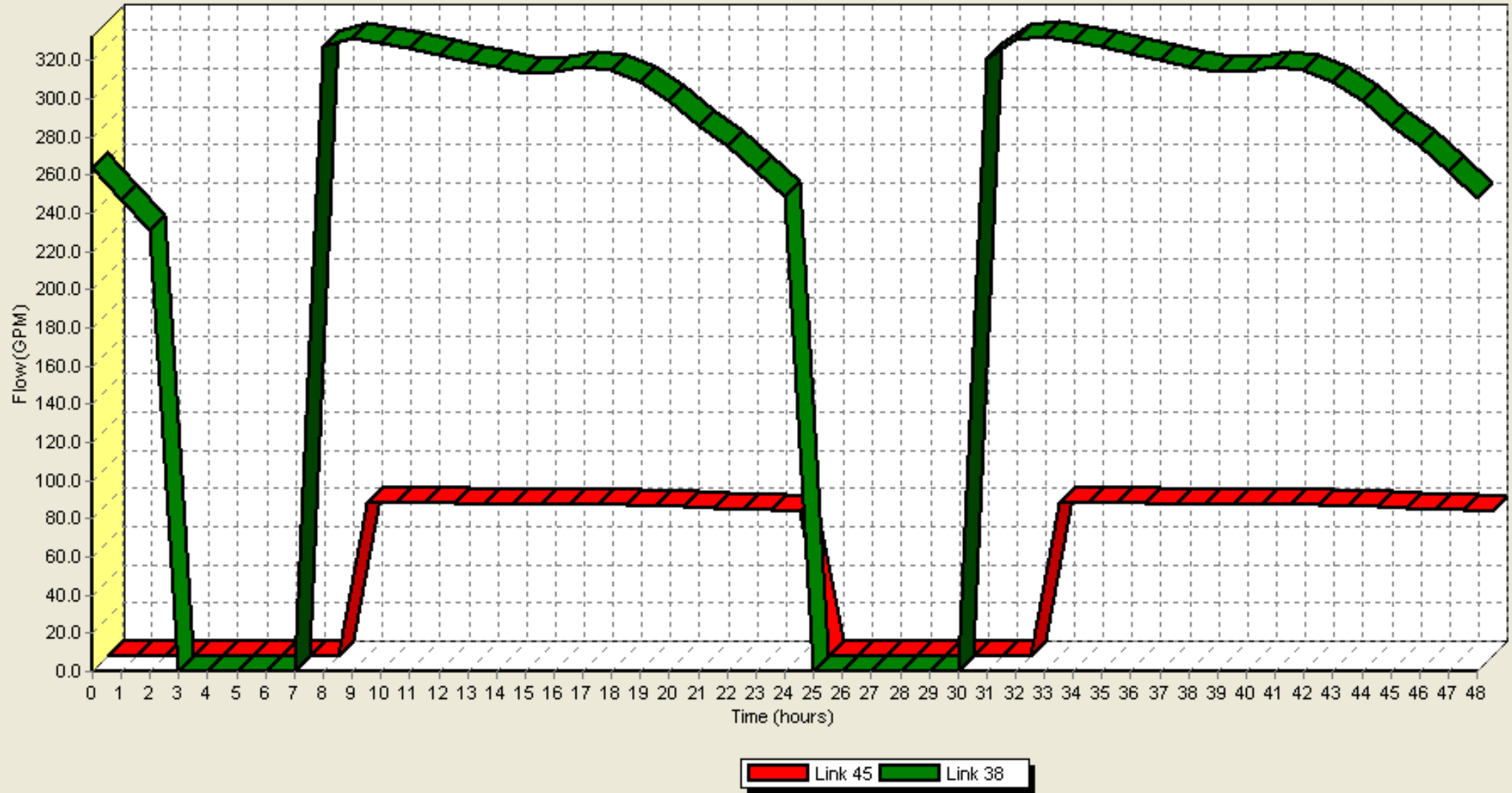

Head in Elevated Tank

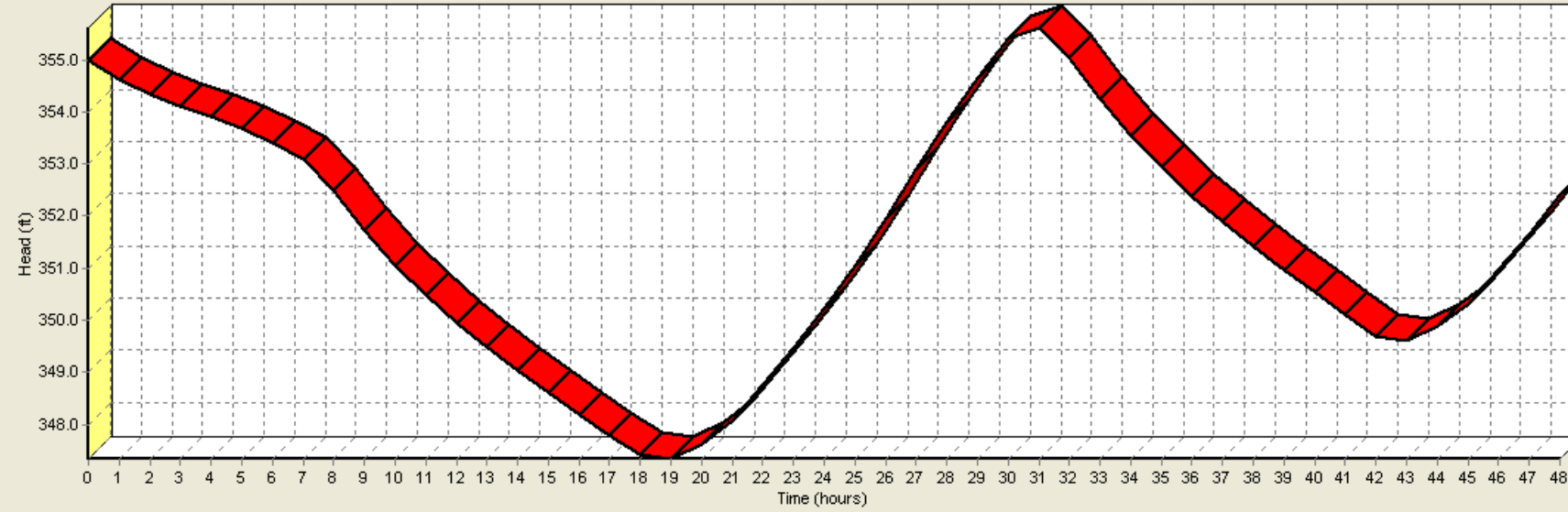

Head in Standpipe

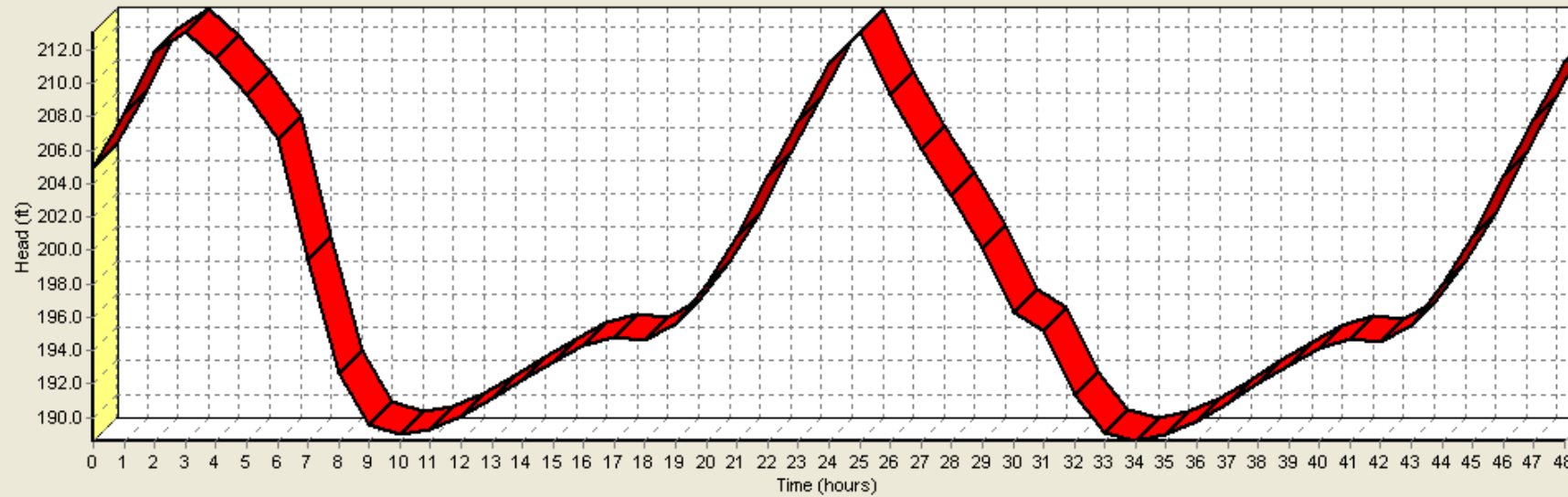

EPANET

A Very Brief Quick Start Hands-on Orientation Using Model of SmallWater USA

Input file: SmallWater-quick start demo.net